

ML312 T-type Pod

Pod Series

Description

A compact signal conditioner for use with thermocouples to measure physiological temperatures. The T-type Pod accepts direct connection of T-type thermocouples fitted with miniature flat pin connectors. The output of the Pod is 10 mV/°C in the range 0 to 50 °C.



System Compatibility

The T-type Pod connects to any PowerLab hardware units with Pod ports (8-pin DIN inputs). PowerLab and MacLab (except 4s, 8s and 16s) units without Pod ports require the FE305 Pod Expander.

The T-type Pod is supported by the following versions of ADInstruments software:

WINDOWS

- LabChart v6 or later
- Chart v3.4.8 or later
- Scope v3.6.3 or later
- LabTutor v1.4 or later

MACINTOSH

- LabChart v6 or later
- Chart v3.6.3 or later
- Scope v3.6.3 or later

Note: Earlier software versions do not support Pods.

Visit our website for information on operating system requirements.

Transducer Compatibility

Any T-type thermocouple fitted with a miniature thermocouple connector is suitable for use with the T-type Pod. See ordering information on the back page for a list of T-type thermocouples sold by ADInstruments.

Applications

The T-type Pod is suitable for biological temperature measurements with 0.2 °C accuracy (dependent on temperature range). The ML312 T-type Pod is not galvanically isolated.

Theory of Operation

The thermocouple voltage signal is amplified to produce 10 mV/°C @ 25°C. Ice Point Reference compensation is provided by the direct measurement of the input connector temperature. The equivalent voltage is subtracted from the thermocouple voltage to compensate for the changes in the ambient temperature. Temperature changes are typically slow and filtering is provided by a 2 pole 10 Hz Butterworth filter. This will provide adequate filtering from mains power supply and allow fast temperature transients to be monitored.

Note: The output of the Pod is not linearized.

Operating Instructions

Connect the transducer to the mini thermocouple connector on the rear panel of the T-type Pod. Connect the 8-pin DIN cable from the rear panel of the T-type Pod to a PowerLab Pod port (or one of the Pod ports of a Pod Expander connected to the PowerLab). Do not connect other devices such as Front-ends or Instruments to the corresponding BNC connector on the channel used by the Pod.

Pods can be connected to the PowerLab unit while ADInstruments software is running, but not when recording data. Once detected, the functions of the T-type Pod are combined with those of the PowerLab and software, replacing the Input Amplifier dialog with the T-type Pod dialog (shown below).

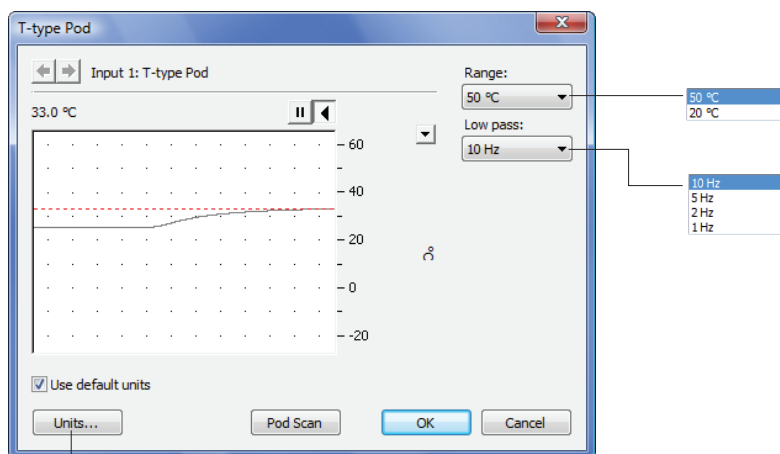

Click this button to view or alter the calibration of the T-type thermocouple.

Stacking and Unstacking Pods

Pods stack by clicking into place on top of each other. To separate stacked Pods, push the top Pod towards the back and then pull them apart from the back. See picture on right.



Typical Data

The data below shows the temperature versus output voltage for a T-type thermocouple probe when connected to a T-type Pod. This table may be used with Chart or Scope Units Conversion or the Chart Multipoint Calibration Extension to provide a more accurate and linear output.

Temp (°C)	Output (mV)
10	97.6
20	196.9
25	247.6
30	298.5
35	350.2
40	402.1
45	454.7
50	507.9

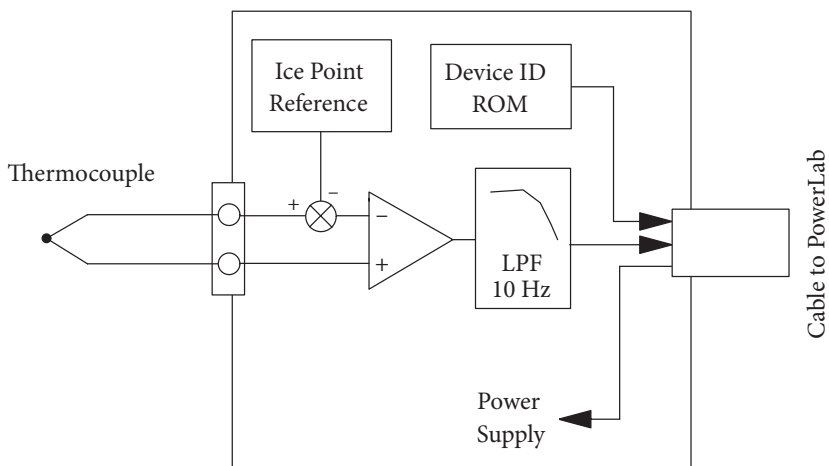

Caution

Read "Statement of Intended Use" on our website or in "Getting Started with PowerLab" before use.

Specifications

Input impedance:	~1 k Ω
Temperature range:	0 to 20 °C or 0 to 50 °C
Output voltage:	10 mV/°C (0 V = 0 °C) non-linearized
Calibration:	Ice point reference calibration provided
Temperature accuracy:	± 0.2 °C 35 to 40 °C ± 0.5 °C 0 to 45 °C ± 1 °C 0 to 50 °C
DC drift:	2 μ V/°C
Response time (T-type Pod only):	~40 ms (10 to 90% of range) Overall response time will depend on the response time of the thermocouple device
Amplifier noise:	1 μ V p-p (0.1 Hz to 10 Hz)
Input connection:	Miniature T-type connector
Weight:	200 g
Enclosure size (l x w x h):	108 x 58 x 35 mm

All specifications were tested at the time of printing and are subject to change.

Ordering Information:a

ML312 T-type Pod

For use with:

MLT1400	General Purpose Thermocouple Probe
MLT1401 (IT-18)	T-type Implantable Thermocouple Probe
MLT1402	T-type Ultra Fast Thermocouple Probe
MLT1403	Rectal Probe for Rats
MLT1404	Rectal Probe for Mice
MLT1405 (IT-21)	T-type Implantable Thermocouple Probe
MLT1406	Needle Microprobe Thermocouple
MLT1407	Large Animal Rectal Probe